

# TELEDATA® SWF1000

## WIRELESS PHOTO DETECTOR

### GENERAL DESCRIPTION

The **SWF1000** wireless optical smoke detector has been designed to fully meet the requirements of European Standard EN54-7. The advanced design of the smoke inlet of the optical chamber guarantees a very high rejection to the introduction of dust, effectively increasing the time between maintenance periods.

An alarm condition is determined when the level of smoke inside the optical chamber exceeds the alarm threshold; consequently an alarm message is sent to the control panel via **FDW2W** translator module.  
Communication between the detector and the **FDW2W** module is wireless, via 'Wireless' bidirectional protocol. The radio communication meets the European Standard EN54-25.

### TECHNICAL SPECIFICATIONS

Topic	Specification	Notes
Communication range with the <b>FDW2W</b>	200 m	Open space
Operating frequency	868.15 MHz - 869.85 MHz	
Modulation type	FSK	
Operating frequency channels	7	
Radiated power	5 dBm (3 mW)	Typical
Transmission message period	60 sec	Default
Main battery	Type CR123A	6.5 years typical
Secondary battery	Type CR2032A	2 months typical
Dimensions	110 mm x 54 mm	
Weight	150 g	Without Batteries
Operating temperature range	From -30 °C to +55 °C	From -10 °C to +55 °C with secondary battery

### PARTS OF THE PRODUCT

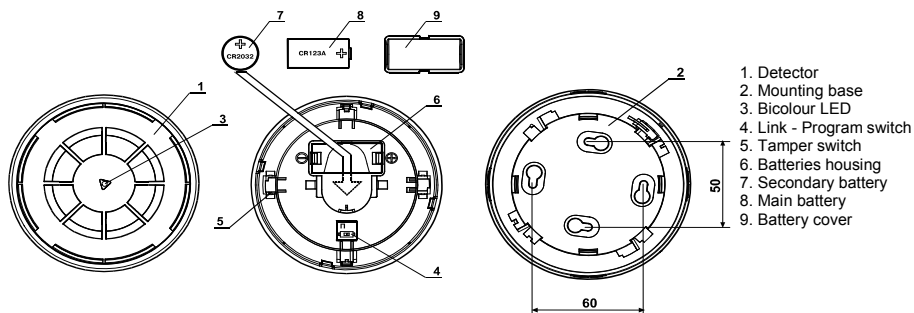

Picture 1

### DETECTOR VISUAL LED INDICATOR

The **SWF1000** detector is equipped with a bicolour LED (red/green) that provides visual indication for functional conditions and battery levels as indicated in table 2.

Device Status	Green LED	Red LED
Switching into operating mode	Short blinks	-
Switching into programming mode	-	4 short blinks
Self-adjustment mode	-	Blinking (1 second on / 0.1 second off)
Normal mode	-	-
Alarm condition	-	Repetitive blinking (0.5 second on / 0.5 second off)
Main battery fault (Low level)	-	Blinking (0.1 second on / 5 seconds off)
Secondary battery fault (Low level)	Blinking (0.1 second on / 5 seconds off)	-
Both batteries fault	Sequential bicolor blinking (0.1 second on / 5 seconds off)	
Fault	Sequential blinking 0.5 second	

Table 2

### DEVICE'S POWER SUPPLY AND LINKING

The linking operation permits the configuration of the **SWF1000** detector on the **FDW2W** translator module. The linking operation described below does not change if made directly from the **FDW2W** translator module or from the PC configuration program; please, refer also to the 'Wireless System Installation Manual'.

1) Verify that the secondary battery is present; if not, insert the battery into its housing with the positive pole facing up (Picture 2).



Picture 2 - Secondary battery housing

2) Move the switch to position ON (Picture 3).

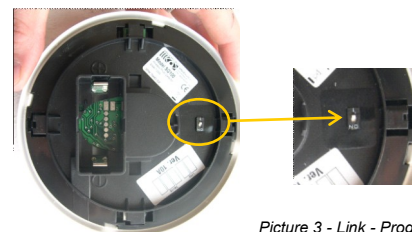

Picture 3 - Link - Program switch

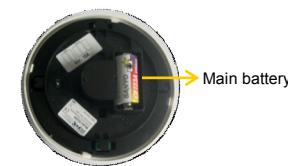

Picture 4 - Main battery

3) Insert the main battery (Picture 4).

**Ensure that battery polarity is correct.**

The visual LED indicator switches green once, then four times red (programming mode) and will, successively, turn off. This indicates that the detector is ready to be linked to the **FDW2W** translator module.

4) Move the switch in position 1 to trigger the communication between the detector and the **FDW2W**.

The green LED switches on once, then it blinks many times (operating mode), successively the red LED blinks many times (self-adjustment mode) and, finally, after alternating green-red for one second, the indicator turns off: this indicates that the linking procedure has been performed correctly and the detector has programmed itself.

The detector is linked and all the parameters (address, system code etc.) necessary to work correctly are stored.

If the LED remains switched on the red light it means that the linking operation failed. In this case remove the main battery, commutate alternatively the ON / 1 switch a few times in order to discharge the internal capacitor and then start again from point 2).

**IMPORTANT NOTE!** Programming is considered to be completed successfully only if there is an indication of programming success on the detector and on the **FDW2W** or on the window of the PC configuration program.

5) Put on the battery cover.

## COMMUNICATION QUALITY ASSESSMENT

It is possible to assess the wireless communication quality of the sensor by using a testing feature built in the device. After a successful linking operation, by commuting the Link-Programming switch on the ON position, the sensor's indicator will start blinking according to table 3.

**Always remember to reposition the switch to 1 after the assessment operation: device will NOT work operatively while the switch is commuted on the ON position.**

Communication quality	Assessment	Device's indication
No connection	Fail	Two red blinks
Link margin is less than 10 dB	Poor	One red blink
Robust communication with link margin from 10 dB to 20 dB	Good	One green blink
Robust communication with link margin over 20 dB	Excellent	Two green blinks

Table 3

## DETECTOR PLACEMENT

For specific information regarding detector spacing, placement and special applications refer to your specific national standards. It is strongly advised to mount the device as far as possible from metal objects, metal doors, metal window openings, etc. as well as cable conductors, cables (especially from computers), otherwise the operating distance may greatly drop. The device should not be installed near electronic devices and computer equipment that can interfere with the reception quality.

- 1) Select the position of the detector before installing and fixing its supporting base. **Verify, from that position, that the communication between the detector and FDW2W is correctly established and working (see the COMMUNICATION QUALITY ASSESSMENT paragraph).**
- 2) Install and fix the base, in the selected position, with the screws provided (Picture 5 and Picture 6).
- 3) Insert the detector into the base (Picture 5).



Picture 5 - Detector placement

## WIRELESS DETECTOR ANTI-TAMPER BLOCK AND REMOVAL

The base for the SWF1000 wireless detector has a special anti-tamper device block. To lock the sensing device onto the base, cut off the small plastic lug on the plastic blocking grip on the detector base (Picture 6).

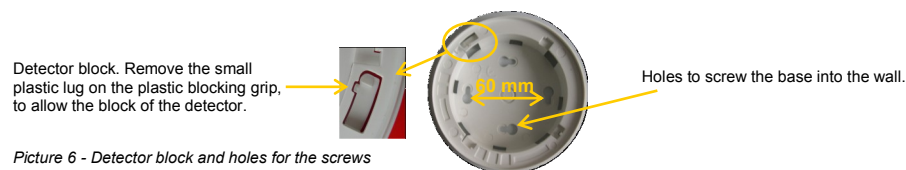

Picture 6 - Detector block and holes for the screws

To remove the blocked detector from the base, insert a tool, like a small screwdriver, into the hole and remove the detector (Picture 7).



Picture 7 - Detector block removal

## TESTING

The SWF1000 detector has been designed to permit a magnetic functional test. When the test is performed with an appropriate magnet, a fire alarm message is sent to the control panel via FDW2W.

To perform the magnetic test put and hold the magnet near the surface of the indicated area (Picture 8). The detector must enter into alarm condition, activate the central LED indicator (blink red as per Table 2) and transmit the alarm message to the control panel.

The detector must be reset by the specific command on the control panel (see the RESET paragraph).

**All detectors must be tested after installation and, successively, on a periodic basis.**

Picture 8 - Magnetic test area

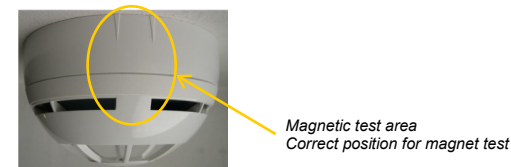

## RESET

To reset the detector from alarm or fault condition it is necessary to send the reset command from the control panel.

## TAMPER DETECTION FEATURE

The SWF1000 detector is provided with a tamper switch and, in case of removal of the detector from its base, it sends a tamper detection message to the control panel (Picture 9).

Picture 9 - Tamper switch



## MAINTENANCE

- 1) Before starting any maintenance work, isolate and disable the system, in order to avoid accidental and unwanted alarm conditions.
- 2) Remove the detector from its mounting base to allow inspection and servicing at ground level and in good light. Inspect the smoke entry ports around the sensor and use a small, soft bristle brush to dislodge any obvious contaminants such as insects, spider webs, hairs, etc.
- 3) Use a small vacuum tube or dry, clean, compressed air to suck up or blow any remaining small particles away from the smoke entry screen area.
- 4) Wipe the exterior housing of the detector with a clean, damp, lint-free cloth to remove any surface film that can later attract airborne contaminants.
- 5) After all detectors have been inspected and serviced, reinstall them in their mounting bases, re-apply power to the system and check correct operation as described under the TESTING paragraph.

## FAULT SELF-TEST

The SWF1000 detector periodically performs a self-test and, if a fault condition is detected, a fault message is sent to the control panel via FDW2W.

The fault condition is locally signaled by the visual LED indicator located at the center of the detector (see Table 2).

A fault condition is determined by:

- a) Fault on the optical analysis path (chamber, electronic circuit, etc).
- b) High level of contamination inside the optical chamber.
- c) Low batteries level.

## WARNINGS & LIMITATIONS

This product uses high quality electronic components and plastic materials that are highly resistant to environmental deterioration. However, after 10 years of continuous operation, it is advisable to replace detectors to avoid the risk of reduced performance caused by external factors. Ensure that these detectors are only used with compatible control panels. Detection systems must be checked, serviced and maintained on a regular basis to confirm correct operation.

Smoke detectors may respond differently to various kinds of smoke particles, thus application advice should be sought for special risks. Detectors cannot respond correctly if barriers exist between them and the fire location and may be affected by special environmental conditions. Refer to and follow National Codes of Practice and other internationally recognized fire engineering standards. Appropriate Risk Assessment should be carried out initially to determine correct design criteria and updated periodically.

## WARRANTY

This product is supplied with the benefit of a limited 3 Year Warranty relating to faulty materials or manufacturing defects, effective from the production date indicated on each product. This warranty is invalidated by mechanical or electrical damage caused in the field by incorrect handling or usage. Product must be returned, via your authorized supplier, for repair or replacement, together with full information on any problem identified.

Full details on our Warranty & Products Returns Policy can be obtained upon request.

**The warranty does not cover the provided batteries.**